

IceCube Summer Student Program Report 2023

Wassachon Kammeemoon | Department of Physics, Mahidol University
Visiting UW-Madison Wisconsin IceCube Particle Astrophysics Center
Date: 1-Jun-2023 to 31-Jul-2023



Name	Wassachon Kammeemoon
Report	Icecube Summer Student Program 2023
Visiting	UW-Madison Wisconsin IceCube Particle Astrophysics Center
Date	1-Jun-2023 to 31-Jul-2023

Contents

1.	Introduction to IceCube Summer Student Program	2
2.	Introduction to IceCube	3
3.	IceCube Summer School (Science and Software Workshop)	5
4.	Scintillator Panel Calibration Project	7
5.	Madison Symmetric Torus (MST) Visiting	7
6.	Helically Symmetric eXperiment (HSX) Visiting	8
7.	Journal Diary	9
8.	Appendix: Scintillator Panel Calibration	29



Name	Wassachon Kammeemoon
Report	Icecube Summer Student Program 2023
Visiting	UW-Madison Wisconsin IceCube Particle Astrophysics Center
Date	1-Jun-2023 to 31-Jul-2023

1. Introduction to IceCube Summer Student Program

An IceCube software workshop is designed for collaborators and students worldwide to participate and learn about IceCube Neutrino Observatory, which was held from June 5th to June 9th, 2023, at Wisconsin IceCube Astrophysics Center (WIPAC). The program aims to provide an opportunity for participants to gain deeper insights into IceCube research alongside IceCubers. Following the software workshop, students will be assigned an IceCube project to work on for a period of one and a half months.

The IceCube Summer Student Program is specially designed for collaboration between Thailand and IceCube. This program is held for 10 weeks or 2 months, providing an opportunity for Thai students to work on projects relevant to IceCube neutrino research.

This year, two students from Thailand, namely

1. Ms. Wassachon Kammeemoon from Mahidol University
2. Ms. Yanee Tangjai from Chiangmai University

have passed the interview examination conducted by the selection committee and have been finally selected by Her Royal Highness Maha Chakri Sirindhorn to attend the IceCube Summer Student Program 2023. They traveled to the United States of America to attend the IceCube Summer Student Program at the University of Wisconsin-Madison from June 1 to July 29, 2023. Their international flights, visa fee, travel insurance, and allowance will be supported by the Information Technology Foundation under the Initiative of Her Royal Highness Princess Maha Chakri Sirindhorn. Their accommodation and meals will be supported by WIPAC.



Name	Wassachon Kammeemoon
Report	Icecube Summer Student Peogram 2023
Visiting	UW-Madison Wisconsin IceCube Particle Astrophysics Center
Date	1-Jun-2023 to 31-Jul-2023

2. Introduction to IceCube

IceCube is a short name of IceCube Neutrino Observatory. IceCube is located at Amundsen-Scott South Pole Station. IceCube finished construction in December 2010. IceCube is supported by the National Science Foundation. IceCube consists of Digital Optical Modules (DOMs) composed of photomultiplier tubes (PMT) and sensors. These sensors will detect Cherenkov light and send signals to the computer in IceCube Lab located on the surface of Antarctica. IceCube is aimed to explore the universe with astrophysics neutrinos. The below figure shows IceCube detector under the ice.

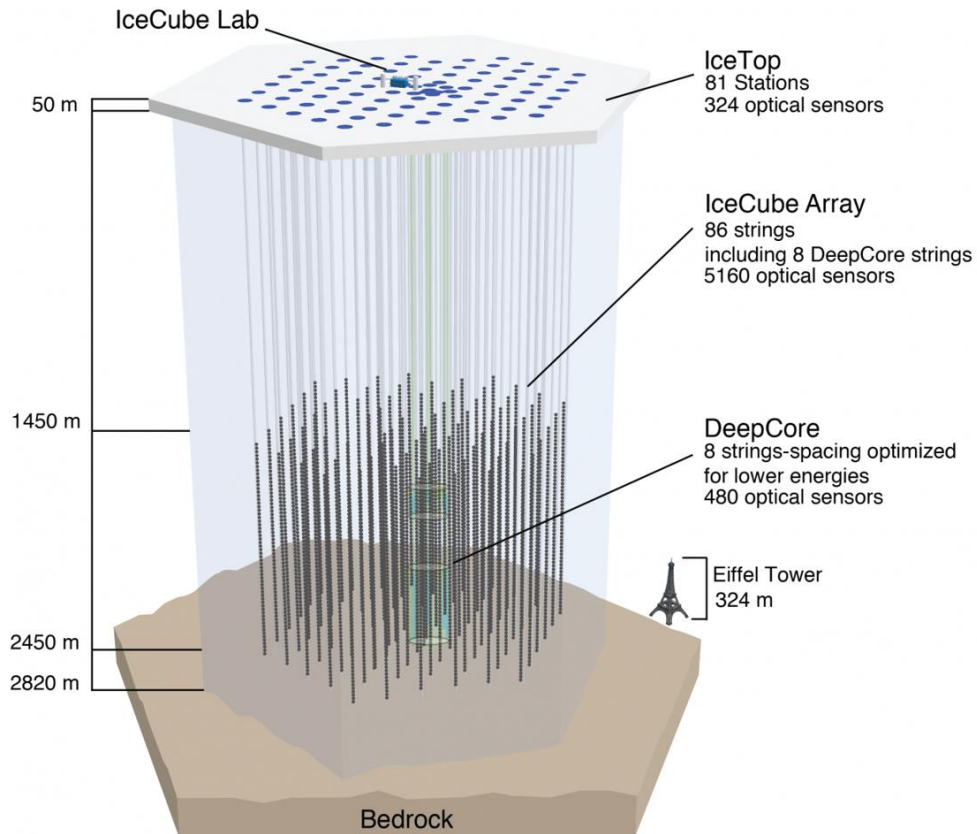

Figure 1 IceCube detector and IceCube Lab.



Name	Wassachon Kammeemoon
Report	Icecube Summer Student Program 2023
Visiting	UW-Madison Wisconsin IceCube Particle Astrophysics Center
Date	1-Jun-2023 to 31-Jul-2023

IceCube Collaboration

There are more than 300 physicists from 57 institutions in 14 countries participated in IceCube.



Figure 2 The IceCube Collaboration

IceCube Working Group

There are 5 Working groups lists below:

Analysis	Technical Working Groups	R&D projects
Oscillations (calls) (mail) ☞	Reconstruction and Systematics (calls) (mail) ☞	Acoustic (calls) (mail) ☞
Cosmic rays (calls) (mail) ☞	Realtime (slack) ☞ (mail) ☞	AURA (calls) (mail) ☞
Diffuse/Atmospheric ν (calls) (mail) ☞	Calibration (calls) ☞ (mail) ☞	RASTA (calls) (mail) ☞
Supernova (calls) (mail) ☞		PINGU
Beyond the Standard Model (calls) (mail) ☞	Detector & Simulation	Proton Decay Simulation
Neutrino Sources (calls) (mail) ☞	Simulation (mail) ☞	IceCube Extensions (mail) ☞
	Simulation Production	IceAct (calls) ☞
		Legacy working groups
		Neutrino Oscillations (calls) (mail) ☞
		Low-energy ν (calls) (mail) ☞
		Extreme energies (calls) (mail) ☞
		Tau & Composites (calls) ☞ (mail) ☞
		Exotic particles (calls) (mail) ☞
		WIMPs/Dark Matter (calls) (mail) ☞
		Transients (calls) (mail) ☞
		Point sources (calls) (mail) ☞
		Cascades/Taus (calls) (mail) ☞
		Muons (calls) (mail) ☞
		Verification (mail) ☞

Please refer to the [wiki calendar](#) or the [upcoming meetings web page](#) ☞ for times and dates of phone calls.

Figure 3 IceCube Working Group

During this summer, I worked mainly with “Calibration group”, a subgroup of the Technical Working Groups. For more details on my work, please refer to Chapter 4, Scintillator Panel Calibration Project.



Name	Wassachon Kammeemoon
Report	Icecube Summer Student Program 2023
Visiting	UW-Madison Wisconsin IceCube Particle Astrophysics Center
Date	1-Jun-2023 to 31-Jul-2023

3. IceCube Summer School (Science and Software Workshop)

IceCube Summer School is an intense workshop that introduces the science of IceCube which relates to the detector, multimessenger astronomy, physics, and statistics, including analysis activity and introduction of IceCube software. The workshop was five days, starting on 5-Jun-2023 and ending on 9-Jun-2023. The timetable of the programs is shown below:

5-Jun-2023	
08:50-09:00	Introduction
09:00-09:30	IceCube Science
09:30-10:00	IceCube Detector
10:00-11:00	Multimessenger and Astrophysics
11:00-11:30	Neutrino Physics & Oscillation
11:30-11:45	Diversity, Equity, and Inclusion
13:00-14:00	Advanced Python
14:30-15:30	Coding Best Practice
16:00-18:00	Social events: Welcome Social @ the Terrace
6-Jun-2023	
09:00-09:30	South Pole
09:30-10:00	IceCube Upgrade
10:30-12:00	Intro to IceTray
13:00-14:00	I3 File Tools & SteamShovel
14:30-15:30	GitHub Tutorial
15:30-16:30	Into to Statistics
7-Jun-2023	
09:30-10:00	Cosmic Rays
10:30-11:00	Diffuse neutrinos -from TeV to EeV
11:00-11:30	Detector Physics
11:30-12:30	Advanced Statistics
14:10-14:30	Early Career Scientists
14:30-16:30	Calibration and Ice Models
8-Jun-2023	
09:30-10:00	Neutrino Detection with radio antennas
10:00-10:30	Analyses in IceCube
11:00-12:30	Distributed Computing -NPX
13:30-14:00	Using the Grid
14:00-14:30	Point Sources
14:45-16:00	Point Source exercise - worktime



Name	Wassachon Kammeemoon
Report	Icecube Summer Student Program 2023
Visiting	UW-Madison Wisconsin IceCube Particle Astrophysics Center
Date	1-Jun-2023 to 31-Jul-2023

9-Jun-2023

09:00-09:30	Event selection
09:30-10:00	IceCube-Gen2
10:30-11:00	Filtering
11:00-11:30	Event Reconstruction
11:30-12:00	Simulation
13:00-13:30	Diffuse Exercise
13:45-15:00	Diffuse Exercise -worktime
09:00-09:30	Event selection

In the IceCube Summer School, I have learned about IceCube Detector and the output data from IceCube, data analysis, neutrino physics, data visualization using IceCube's software, statistics, IceCube upgrade, and cosmic rays. They also had hands-on activities which let me play with their data. It was an excellent experience to complete this workshop.



Name	Wassachon Kammeemoon
Report	Icecube Summer Student Program 2023
Visiting	UW-Madison Wisconsin IceCube Particle Astrophysics Center
Date	1-Jun-2023 to 31-Jul-2023

4. Scintillator Panel Calibration Project

IceTop is a surface array of the IceCube. An IceTop station includes 8 scintillator panels, 2 IceTop tanks, 3 Antennas, and 1 field hub. The scintillator panels are used for calibration of snow accumulation impact on the cosmic-ray shower reconstruction that was detected by IceTop and improve the veto capabilities of IceTop. In the summer project, we have new scintillator panels shipped from The Karlsruhe Institute of Technology (KIT), Germany. We must calibrate 48 scintillator panels for 6 stations before shipping them to the south pole.

At Physical Science Lab (PSL), we unpacked a box of scintillators panel and then moved the scintillator panels to a freezer. After that we take data remotely from our office. Every week, we also have a meeting to report progress of the calibration.



Figure 4 Setting scintillators inside a freezer (left), a box of scintillator panels (middle), a weekly meeting (right)

5. Madison Symmetric Torus (MST) Visiting

The Madison Symmetric Torus (MST) produces toroidal plasmas, typically in either reversed field pinch (RFP) or low-safety-factor tokamak geometries. The RFP plasma represents a system in itself that simultaneously exhibits features of the frontier plasma science processes of reconnection, turbulence, particle energization, dynamo and coherent structure formation. It can also provide a fusion grade high temperature plasma with confinement times similar to a comparable-sized tokamak. The MST device gives users access to a well characterized toroidal plasma with a comprehensive suite of diagnostics.

Follow link for more information: <https://wippl.wisc.edu/madison-symmetric-torus>

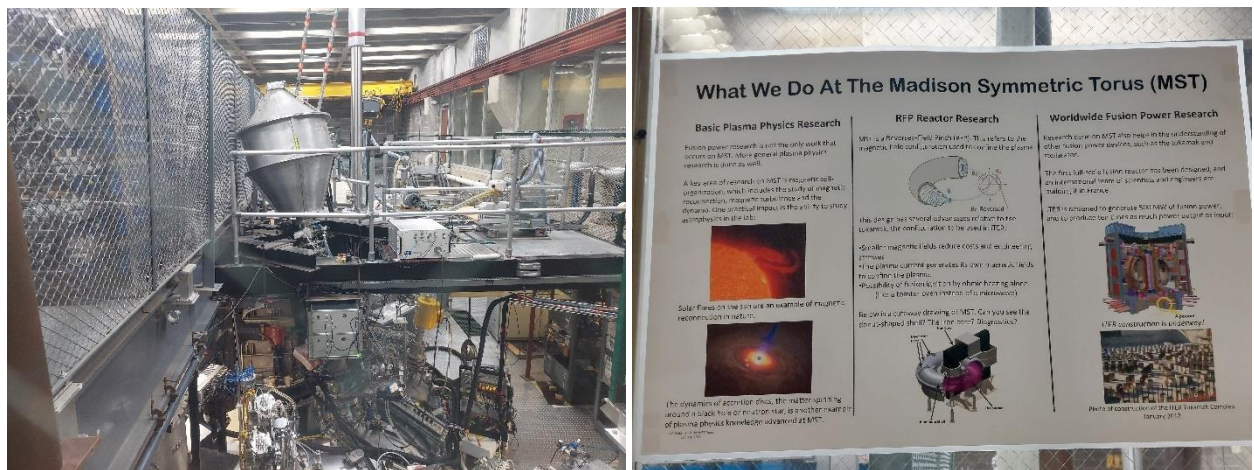

Figure 5 The plasma laboratory at department of Physics, UW-Madison



Name	Wassachon Kammeemoon
Report	Icecube Summer Student Program 2023
Visiting	UW-Madison Wisconsin IceCube Particle Astrophysics Center
Date	1-Jun-2023 to 31-Jul-2023

6. Helically Symmetric eXperiment (HSX) Visiting

The Helically Symmetric eXperiment (HSX) is an optimized stellarator operated by the College of Engineering at UW-Madison. 48 3D shaped coils are used in a torus-like arrangement to produce a 1 Tesla magnetic field that confines high temperatures plasma with temperatures higher than 10-million-degree C. The goal of the experiment is to contribute to the physics basis of a future power plant which produces energy by fusing Hydrogen isotopes to Helium.

Follow link for more information: <https://hsx.wisc.edu/>

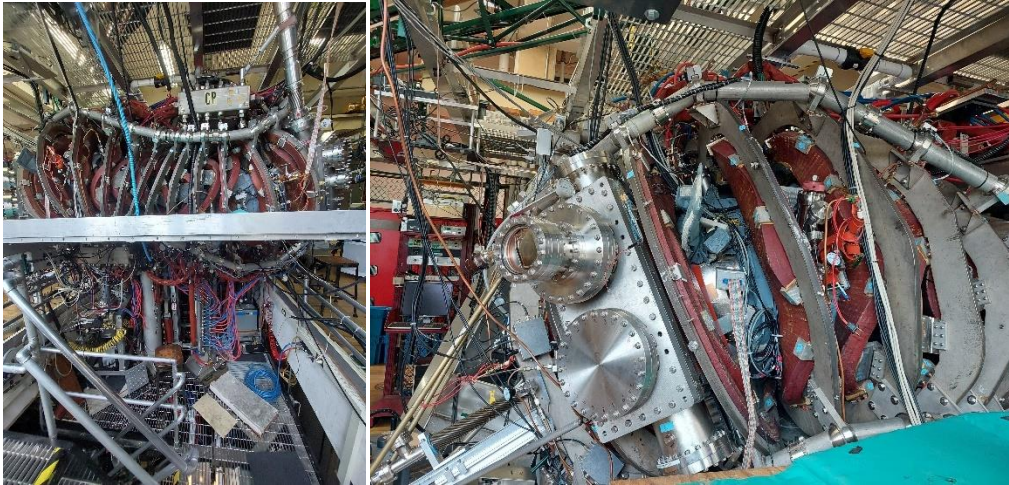

Figure 6 The Helically Symmetric eXperiment (HSX)



Name	Wassachon Kammeemoon
Report	Icecube Summer Student Program 2023
Visiting	UW-Madison Wisconsin IceCube Particle Astrophysics Center
Date	1-Jun-2023 to 31-Jul-2023

7. Journal Diary

June 1, 2023 (+7 GMT)

I woke up and stretched my arms with a delightful feeling. Today was one of the most exciting days of my life. I would travel for the longest time and longest distance since I was born. This journey would be my first experience in the USA.

It was very early morning at Suvarnabhumi Airport. I had to say goodbye to my soulmate. After a farewell, I got on the plane with All Nippon Airways (ANA). I was very impressed with the meals on this airline (especially cold noodles). After over 15 hours of travel, I finally arrived at the University of Wisconsin-Madison (UW-Madison). However, I arrived in Madison after sunset so I couldn't see anything clearly. I just felt the weather was great, but the environment was not judged by my eyes.





Name	Wassachon Kammeemoon
Report	Icecube Summer Student Program 2023
Visiting	UW-Madison Wisconsin IceCube Particle Astrophysics Center
Date	1-Jun-2023 to 31-Jul-2023

June 2, 2023 (-5GMT)

I woke up early than usual because in Madison the sun rises very early than in Thailand. This was the first time I saw the building in UW-Madison clearly. It was a great view from the window in my bedroom. The weather outdoors was cool compared with Thailand (seems like the winter in Thailand). Today I was wandering around the city. I went to the Terrace by Mendota Lake. Then, visited the Wisconsin State Capitol. At this place, I found the most elegant architecture that I have ever seen! Now, I fall in love with Madison :)



June 3, 2023 (-5GMT)

Today in the morning I went shopping at Hilldale Shopping Center. In the evening I met P.Petch who is an alumnus of Mahidol University and now he is studying at UW-Madison. We had some chit-chat, and I got some suggestions about living in Madison. We planned to cycle around Monona Lake (a lake loop) for tomorrow.



Name	Wassachon Kammeemoon
Report	Icecube Summer Student Program 2023
Visiting	UW-Madison Wisconsin IceCube Particle Astrophysics Center
Date	1-Jun-2023 to 31-Jul-2023



June 4, 2023 (-5GMT)

I rode a bicycle around Monona Lake (a lake loop). That's so much fun!! While cycling, I had a chance to visit a botanical garden. There are many fantastic species of plants and a Thai pavilion. After visiting the Thai pavilion, I suddenly missed Thai food haha. Fortunately, there is a Thai restaurant nearby and I could have lunch there. Madison is a good city, with good weather, and good people. Such a great trip!! I finished cycling in the afternoon. In the evening I had to prepare for an IceCube Summer School tomorrow.





Name	Wassachon Kammeemoon
Report	Icecube Summer Student Program 2023
Visiting	UW-Madison Wisconsin IceCube Particle Astrophysics Center
Date	1-Jun-2023 to 31-Jul-2023

June 5, 2023 (-5GMT)

Today is the first day of the IceCube Summer School. We learned about the introduction to the IceCube. I was extremely excited because I saw the real Digital Optical Module (DOM). I was impressed with WIPAC because the colleagues were nice, and they raised the LGBTQ+ issue. Moreover, I could get dressed informally but comfortably at school. In the evening, we went to a picnic point near our dorm and by Mendota Lake. Normally, there was a beautiful sunset at the picnic point but today is very cloudy. We planned to go there again on another day to see a beautiful sunset.



June 6, 2023 (-5 GMT)

The IceCube Summer School is still going on. My favorite topics today were statistics and software. After the workshop, I had dinner at Haugen's house. Cherry is Thai and her husband, Jim used to work at IceCube. I had a quick tour at Jim's house. It was a great dinner because I had Thai food, met Thai people in Madison, and was talking about IceCube.





Name	Wassachon Kammeemoon
Report	Icecube Summer Student Program 2023
Visiting	UW-Madison Wisconsin IceCube Particle Astrophysics Center
Date	1-Jun-2023 to 31-Jul-2023

June 7, 2023 (-5GMT)

Today is the third day of IceCube Summer School. I was still learning about IceCube. In the evening, my team and I had dinner at the Japanese restaurant. Although I had Asian food, but I still missed Thai foods :(





Name	Wassachon Kammeemoon
Report	Icecube Summer Student Program 2023
Visiting	UW-Madison Wisconsin IceCube Particle Astrophysics Center
Date	1-Jun-2023 to 31-Jul-2023

June 8, 2023 (-5GMT)

Today is the fourth day of the IceCube Summer School. Everything is going well. In the evening we went to Jim's house with Albrecht. He cooked many delicious foods for us. After having dinner, we went back to our dorm but while we were cycling back, there was a Madison night market that would be held once a month. There is live music and many shops. That looks like a walking street in Thailand.



June 9, 2023 (-5GMT)

Today is the last day of IceCube Summer School. We discussed a project that we must do during this summer with John Kelley. The project is about scintillator panels. After finishing the school, we celebrated with a shabu-shabu party. That made me get over missing Thai food.



June 10, 2023 (-5GMT)

IceCube Summer School has finished. Today is Saturday, so I could take a rest. I went to a farmer market at the state capitol. There were many local produces from farmers, and I got maple syrup and cheese curd. The weather today is quite hot, so we didn't take time for so long.



Name	Wassachon Kammeemoon
Report	Icecube Summer Student Program 2023
Visiting	UW-Madison Wisconsin IceCube Particle Astrophysics Center
Date	1-Jun-2023 to 31-Jul-2023



June 11, 2023 (-5GMT)

It was raining all day. The weather was very cold, cloudy, and windy. The temperature outside was around 11 degrees Celsius. Today is my birthday. We celebrated with American-style food at east town mall. I was very happy with everything except the weather.



June 12, 2023 (-5GMT)

The weather today is colder than yesterday, but I felt warmer than yesterday. Today was the first day at work. I had my own working table in WIPAC office. My table is next to Yanee's. We discussed a scintillator project with Matt, and we planned to go to work at Physical Sciences Lab (PSL) that is about 20 minutes away from WIPAC on the Wednesday.



Name	Wassachon Kammeemoon
Report	Icecube Summer Student Program 2023
Visiting	UW-Madison Wisconsin IceCube Particle Astrophysics Center
Date	1-Jun-2023 to 31-Jul-2023



June 13, 2023 (-5GMT)

Today I was working at WIPAC (222 building). I have reviewed the journal to prepare information for tomorrow's field trip. In the afternoon, I joined the x-meeting. The x-meeting is a weekly meeting that we can learn the various topics of the IceCube in a quick introduction. Moreover, we can present our project in the x-meeting. Yanee and I are still studying our work, so we might present our project at the end of summer program.

June 14, 2023 (-5GMT)

My team, Matt and I went to the Physical Science Lab (PSL). We unpacked the scintillators from the south pole and saw what we must do. The 8 scintillators were unpacked. In the testing, we must vary the temperature, so we put the scintillators into the -40-degree Celsius freezer. The scintillators are very heavy, we strongly carried them and had a backache later. The field trip today was exciting, so I rather enjoyed it. After finishing work at PSL, we went to Hilldale shopping center. The weather in Madison is dry, so I bought some moisturizer and hand cream. After finished the day, I was extremely exhausted.



Name	Wassachon Kammeemoon
Report	Icecube Summer Student Program 2023
Visiting	UW-Madison Wisconsin IceCube Particle Astrophysics Center
Date	1-Jun-2023 to 31-Jul-2023



June 15-16, 2023 (-5GMT)

These days, there was nothing special. I was studying about the scintillator and all knowledge about the scintillator project.

June 17, 2023 (-5GMT)

In the morning, I went to Albrecht's house and had some coffee. After that, we went to Penn Park to be volunteers on an IceCube outreach activity. In this activity, I was having fun with children and acknowledging people about an IceCube. It was a good experience.



Name	Wassachon Kammeemoon
Report	Icecube Summer Student Program 2023
Visiting	UW-Madison Wisconsin IceCube Particle Astrophysics Center
Date	1-Jun-2023 to 31-Jul-2023



June 18, 2023 (-5GMT)

My team and I discussed and reviewed papers related to work that we have to do so that we could understand clearly about our work before doing it.

June 19-22, 2023 (-5GMT)

These days I was still studying and preparing information before analyzing data from scintillators in freezer.



Name	Wassachon Kammeemoon
Report	Icecube Summer Student Program 2023
Visiting	UW-Madison Wisconsin IceCube Particle Astrophysics Center
Date	1-Jun-2023 to 31-Jul-2023

June 23, 2023 (-5GMT)

Today was one of the most exciting days in Wisconsin, Grace, Fhon's student from Manitowoc drove to Madison and picked up us to her house at Manitowoc by Lake Michigan. We travelled around 2 hours to Lake Michigan, and we met Grace's mom, Lisa. After that, we had lunch at Harry's Prohibition Bistro restaurant in Sheboygan. This restaurant was awesome, there were alcoholic drinks and delicious foods. Before we went to Grace's house we visited a lighthouse by the Lake Michigan. Grace's house is a warm house with a warm style design that made me feel good to be there. After a long day, we took a rest and prepared for rafting tomorrow.

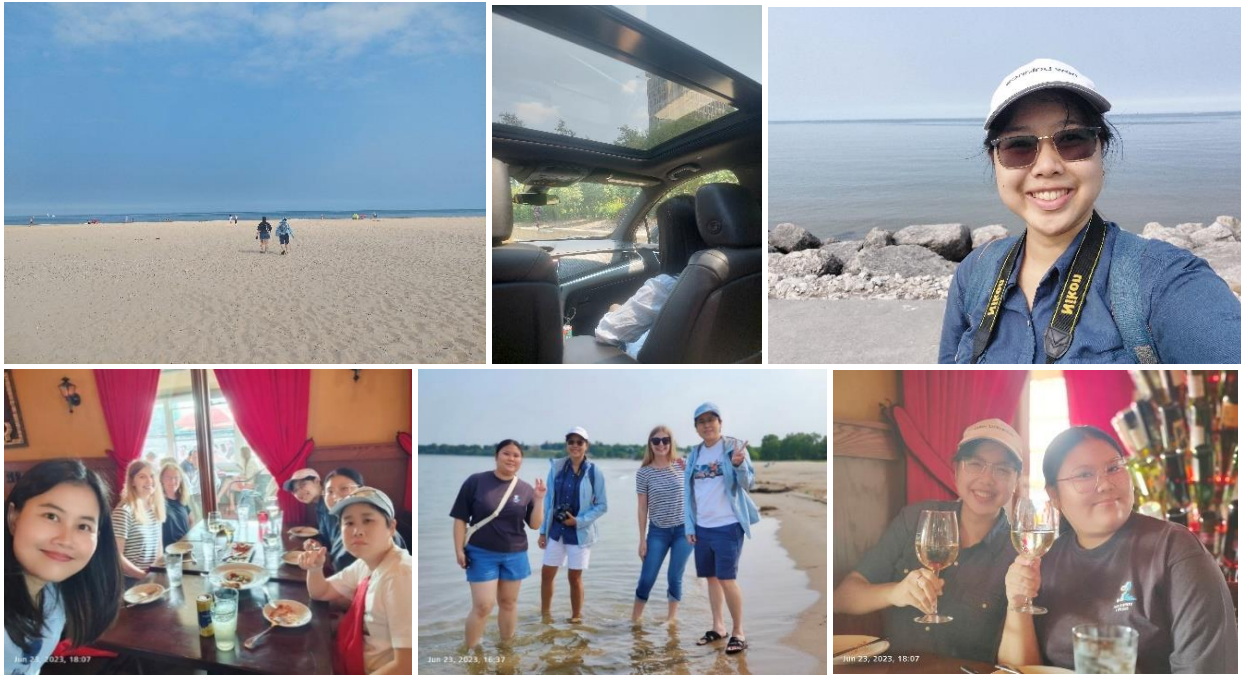

June 24, 2023 (-5GMT)

Today I had an unforgettable experience. We went rafting along Wolf River. It was the most extreme activity I have ever done. The river was very rapid. I also lost my glasses there but fortunately I had a spare one. After rafting, we went to the Wharf Manitowoc restaurant to have dinner there. At this restaurant, there was live music and people were dancing in front of the stage. So, I also joined dancing and it was also my first time joining this activity.





Name	Wassachon Kammeemoon
Report	Icecube Summer Student Program 2023
Visiting	UW-Madison Wisconsin IceCube Particle Astrophysics Center
Date	1-Jun-2023 to 31-Jul-2023

June 25, 2023 (-5GMT)

We went to Wisconsin Maritime Museum to visit the submarine, USS Cobia. It was also my first time to get in the submarine. Inside the submarine was quite narrow, but still fascinating and full of equipment. After visiting the museum, it was time to say goodbye to Lisa. Then it started raining, and Grace took us back to Madison. During those three days with Grace and mom, I did many things for the first time. It was a great and unforgettable experience.



June 26, 2023 (-5GMT)

There was nothing special for today. We discussed work and planned to have a meeting on every Friday.

June 27, 2023 (-5GMT)

In the morning, I had breakfast at Four Lakes Market as usual. There was avocado toast, and I found that I love to eat Avocado more than I thought. After that I went to work. In the evening, Albrecht invited us to join a party for Emanuel's graduation at the terrace. This is a great opportunity to congratulate Emanuel and talk with IceCubers.



July 1, 2023 (-5GMT)

Jim picked us up in the morning to go to Paul's house (Jim's brother's house). We went to Paul's house to celebrate the 4th of July although it was 1st of July and celebrated Jim's niece graduation. There were plenty of foods in American style. It was my first-time trying venison. I met many people and enjoyed playing games. After the party, Jim took us to his cottage. The cottage was by the lake. We could see the fireflies and fireworks from the windows. We would stay in the cottage for a night.



Name	Wassachon Kammeemoon
Report	Icecube Summer Student Program 2023
Visiting	UW-Madison Wisconsin IceCube Particle Astrophysics Center
Date	1-Jun-2023 to 31-Jul-2023



July 2, 2023 (-5GMT)

I woke up in the cottage. Jim and Yanee prepared scones for us. Then Jim, Yanee and I went fishing. Jim told us that there are three types of fish in this lake who usually swim by the shore. That are catfish, carp, and sheepshead. Jim caught a sheepshead fish but the only one fish we ate was carp. So, Jim let it go. After that we went on the boat and went around. Jim taught me how to drive a boat. I saw an osprey while driving a boat. Then Yanee and I went for a walk with Jim's wife's sister and a dog named Chance. We walked around the cottage. After that, Yanee and I helped Jim cook salad, corn, grilled beef, lamb, and salmon. After finished dinner, we went back to our dorm.



July 3, 2023 (-5GMT)

Today is pre-4th of July. I worked in the common room at Phillips residential hall.

July 4, 2023 (-5GMT)

Today is a holiday. Most people didn't go to work. So, Yanee and I decided to work at our dorm. In the evening, we went to see fireworks at a golf course near metro market.



Name	Wassachon Kammeemoon
Report	Icecube Summer Student Peogram 2023
Visiting	UW-Madison Wisconsin IceCube Particle Astrophysics Center
Date	1-Jun-2023 to 31-Jul-2023



July 5, 2023 (-5GMT)

Today I went to work as usual. Unfortunately, it was raining in the evening. So, I got wet when I went back to the dorm.

July 6, 2023 (-5GMT)

Today Yanee and I had diarrhea, so we decided to work at our dome until we recovered.

July 7, 2023 (-5GMT)

Today I went to work as usual. In the evening, we went to the faculty of engineering, UW-Madison. We visited the Helically Symmetric eXperiment (HSX). And then, we visited quantum laboratory, department of physics.

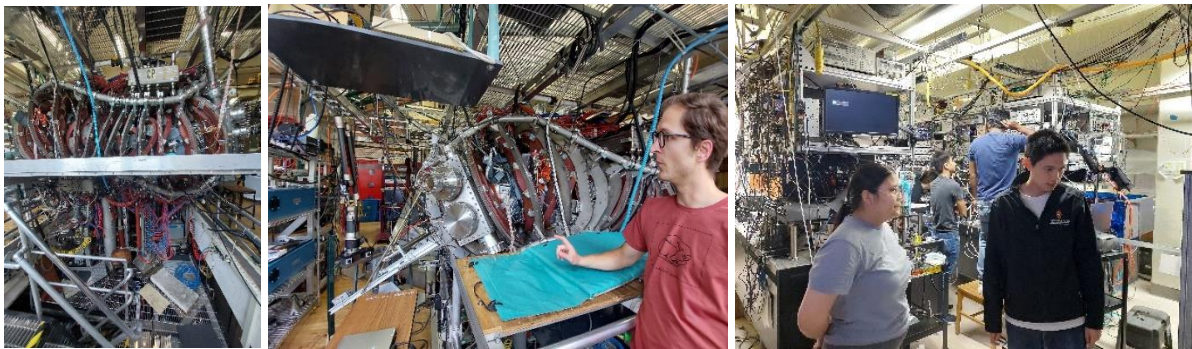

July 8, 2021 (-5GMT)

The weather today was very good. Yanee and I had lunch at a Thai food restaurant on the state street. Surprisingly, there is Kanomjeen authentic Thai food. It was very yummy! We went to a museum. Fortunately, this day and all this week is an art fair on the square. I realized that in America, they give importance to every knowledge no matter if it is science, history, or art.



Name	Wassachon Kammeemoon
Report	Icecube Summer Student Program 2023
Visiting	UW-Madison Wisconsin IceCube Particle Astrophysics Center
Date	1-Jun-2023 to 31-Jul-2023

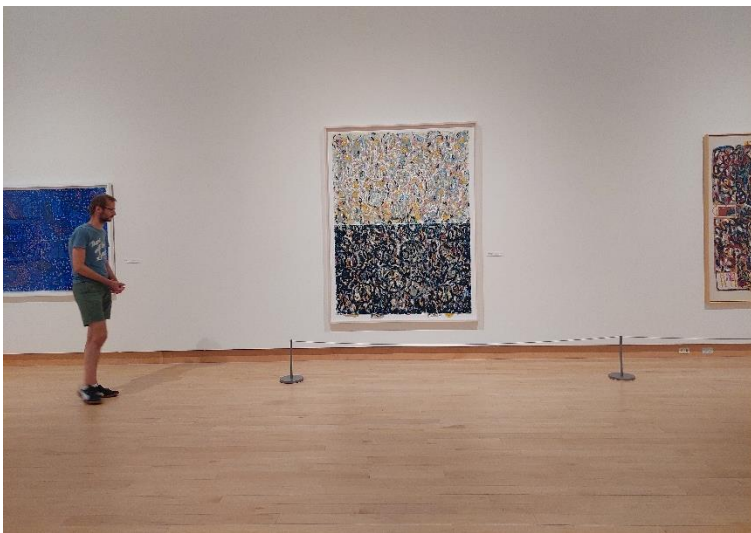

July 9, 2023 (-5GMT)

Today we had brunch at Chinese restaurant. In the evening, we went to Albrecht's house to have dinner there. I met colleagues and had some talk with them.





Name	Wassachon Kammeemoon
Report	Icecube Summer Student Program 2023
Visiting	UW-Madison Wisconsin IceCube Particle Astrophysics Center
Date	1-Jun-2023 to 31-Jul-2023

July 10, 2023 (-5GMT)

Hello Monday! I went to work as usual. Today we discussed the problem with Albrecht. The freezer temperature changes very slowly, so Albrecht suggested we should plot the relation between time and temperature to see when it will be constant. John helped us to do bash script. I was very appreciative.

July 11, 2023 (-5GMT)

Today there was a lot of stuff to do. I continued my work and did more things from Albrecht's suggestion. Everything was going well. In the afternoon, I joined x-meeting, and IceCubers practiced their presentation to prepare for ICRC.

July 12, 2023 (-5GMT)

Today it was a rainy day. Yanee and I were working from our dorm. I continued our work. I tried to make a python script to analyze the relationship between time and temperature. And we almost finished the temperature and voltage scan.

July 13, 2023 (-5GMT)

Today I prepared work for tomorrow's meeting. I have been working on time vs temperature plots from Albrecht's suggestion.

July 14, 2023 (-5GMT)

Today there was a meeting with Albrecht, John and Matt. We reported our work progress. We discussed and got some suggestions for our work.

July 15, 2023 (-5GMT)

Saturday is a rest day. I went to Devil's lake with Yanee, P.Petch, P.Li, and P.Deer. We spent 45 minutes getting there, hiking for around 2 hours, and then kayaking for around 1 hour. After that, we went to Wisconsin Dells, a tourist city in Wisconsin. There were many theme parks in Wisconsin Dells. I felt like it looks like Pattaya in Thailand. We didn't get inside the theme parks, but we were walking around a city and had dinner there. Yanee and I arrived at our dorm around 4 PM, it was both an exhausting and fun day.



July 16, 2023 (-5GMT)

Today is the last day of Maxwell Street festival. The shops on State Street had discounts. Yanee and I were walking along State Street all day.

July 17, 2023 (-5GMT)

Yanee and I reported our work to Fhon. In the evening, Albrecht invited us to have dinner at Pizza Brutta.



Name	Wassachon Kammeemoon
Report	Icecube Summer Student Program 2023
Visiting	UW-Madison Wisconsin IceCube Particle Astrophysics Center
Date	1-Jun-2023 to 31-Jul-2023

July 18, 2023 (-5GMT)

Today we went to work. In the evening, Yanee, P.Petch and I went riding a bicycle to the Arboretum. After that I went to Asian Midway Market to buy some ingredient to cook for a dinner.



July 20, 2023 (-5GMT)

Today I went to work. In the evening, Yanee and I went to relax at terrace. We thought that we nearly to go back to Thailand, so it was a time to explore more in Madison city. We cycled around the capital and a city at night with good weather. It was a great vibe.

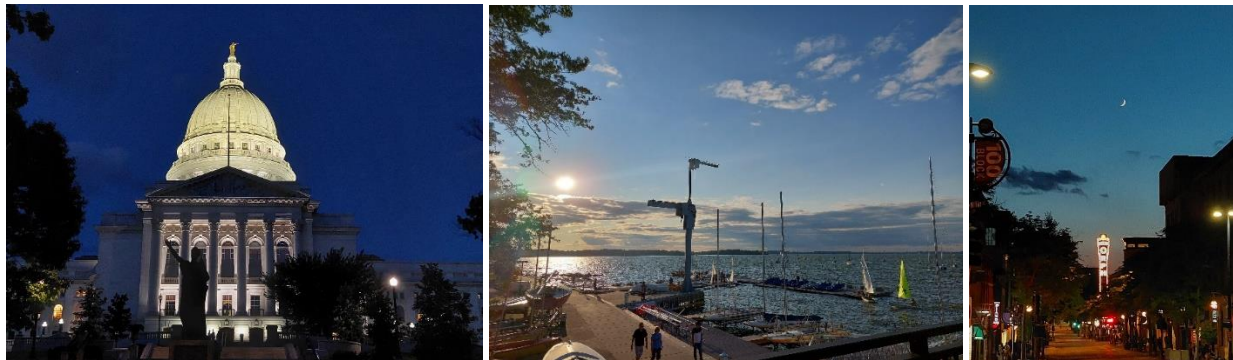

July 21, 2023 (-5GMT)

Today after work, we went to explore Madison again. We went to terrace by Monona Lake at night, and near the capital, there was a concert.

July 22, 2023 (-5GMT)

Today we had a party with Thai people in Madison. There were Thai foods. One of that was grilled pork. Unfortunately, it was rainy, so we had to move to P.Li's room.

July 23, 2023 (-5GMT)

Today was Sunday. Yanee and I went to Hilldale shopping center to buy souvenirs and some ingredients for cooking.



Name	Wassachon Kammeemoon
Report	Icecube Summer Student Program 2023
Visiting	UW-Madison Wisconsin IceCube Particle Astrophysics Center
Date	1-Jun-2023 to 31-Jul-2023

July 24, 2023 (-5GMT)

Today Yanee and I worked from home. After that, we went to the Henry Villas Zoo. We expected that we would see a polar bear, but in the summer, there is no polar bear to show. There was a grizzly bear instead. I saw many animals that I have never seen, for example badgers, a grizzly bear, and piranha.



July 25, 2023 (-5GMT)

Today we work at our dorm. I started to prepare some stuffs for going back to Thailand. In the evening, I visited a plasma laboratory in the department of Physics, UW-Madison, which is P.Petch's research group. The plasma confinement is different from the HSX.



July 26, 2023 (-5GMT)

Today is the last day at the office and the PSL. In the morning, I worked at the office. In the afternoon, I went to the PSL to set up another scintillator box in a freezer.



Name	Wassachon Kammeemoon
Report	Icecube Summer Student Program 2023
Visiting	UW-Madison Wisconsin IceCube Particle Astrophysics Center
Date	1-Jun-2023 to 31-Jul-2023



July 27, 2023 (-5GMT)

Today I packed stuffs in the luggage for going back to Thailand. In the evening, Jim took us to a Mexican restaurant for a farewell. It was the best Mexican restaurant for me. After dinner, Yanee and I stopped at the Le C's café. I ordered a bubble milk tea, and it was the best milk tea in Madison for me. Although I met these two places on the last day in Madison, I am still happy. I hope I will be here again :)



July 28, 2023 (-5GMT)

I left Wisconsin today morning and took the road to Chicago by bus. Downtown Chicago is a big city with many huge buildings that are very different from Wisconsin. I stayed at the hotel near the Millennium Park. After checked-in at the hotel, I visited The Bean (Cloud gate) at the Millennium Park. Then, I went to the Signature Room at the 95th floor restaurant. The view from the restaurant's window was fascinating. Then Yanee and I walked back to the hotel to absorb the atmosphere of Chicago at night. Today is one of my favorite days in the US.





Name	Wassachon Kammeemoon
Report	Icecube Summer Student Program 2023
Visiting	UW-Madison Wisconsin IceCube Particle Astrophysics Center
Date	1-Jun-2023 to 31-Jul-2023

July 29, 2023 (-5GMT)

Finally, I have to say goodbye to America. It was an unforgettable and impressive experience. I met many people, saw different cultures, and learned many things. I got inspiration and motivation for living and learning. Glad to meet you, Madison. I hope I will be here again.





Name	Wassachon Kammeemoon
Report	Icecube Summer Student Program 2023
Visiting	UW-Madison Wisconsin IceCube Particle Astrophysics Center
Date	1-Jun-2023 to 31-Jul-2023

8. Appendix: Scintillator Panel Calibration

8.1 Introduction

The scintillator panels are used for calibration of snow accumulation impact on the cosmic-ray shower reconstruction that was detected by IceTop and improve the veto capabilities of IceTop.

We calibrate the scintillator panels to work well in various extreme temperatures. The aim of this calibration is to get the fitting function and fitting constant of MIP in terms of temperature and voltage. In other words, when the scintillators are in the south pole, each panel is going to get a constant value of MIP. When the temperature changes, the scintillators will change their voltage to maintain the MIP value. For this reason, our calibration and fitting constants are important.

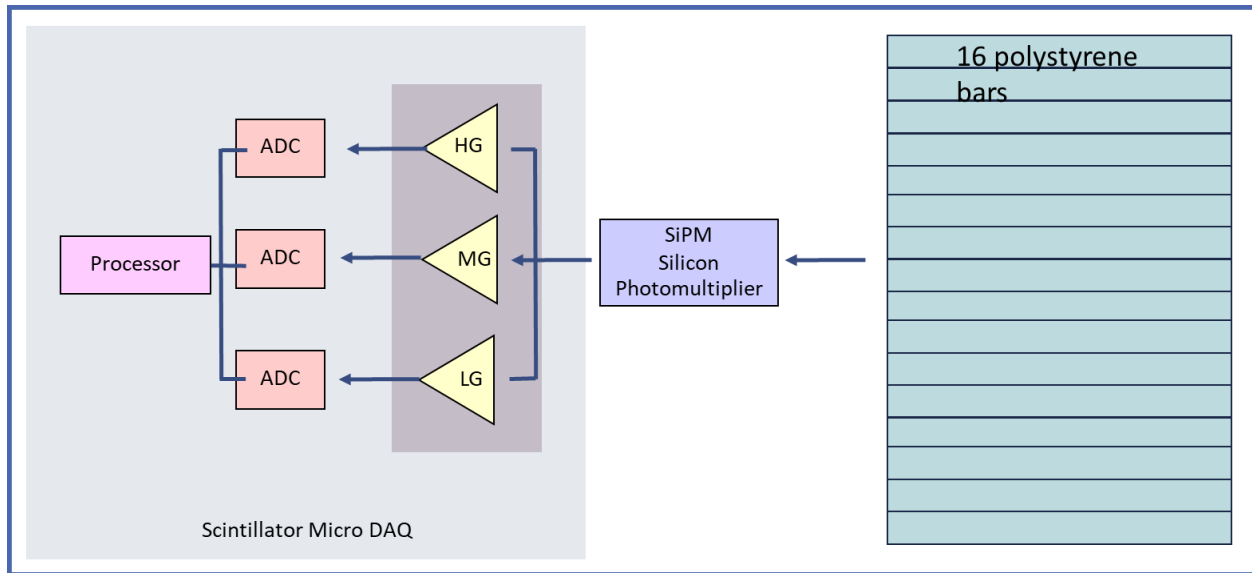

Figure 7 A block diagram of a scintillator panel

8.2 Methodology

First, we unpacked a box of scintillator panels and set them up inside a freezer at the Physical Science Lab (PSL). Then, we can take the data from scintillator panel through a TAXI01 system remotely at our office. Finally, we analyzed the data using IceCube JupyterHub. In the temperature-voltage scan, we set the config of voltage and collect data for each temperature. In the threshold scan, we set config of threshold and collect data in the various temperatures. However, we can also change the freezer temperature remotely through the TAXI01 system.

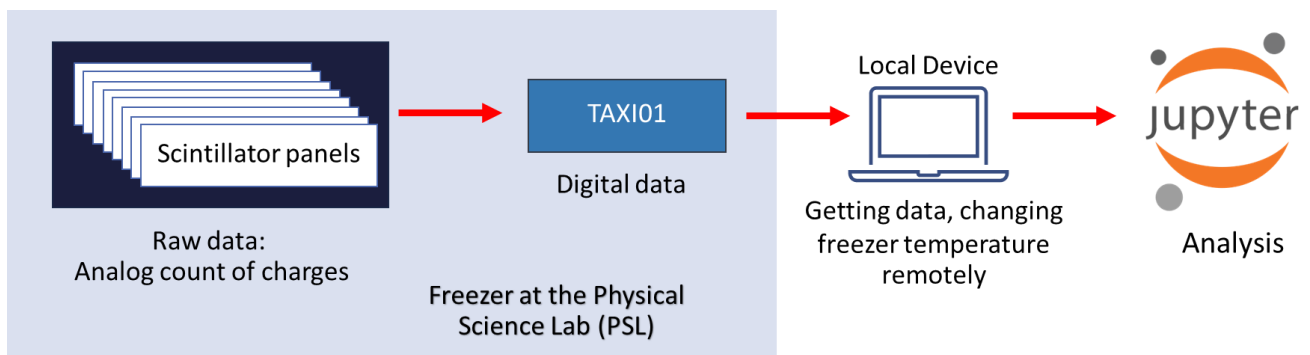

Figure 8 A diagram shows a procedure of scintillator panel calibration



Name	Wassachon Kammeemoon
Report	Icecube Summer Student Program 2023
Visiting	UW-Madison Wisconsin IceCube Particle Astrophysics Center
Date	1-Jun-2023 to 31-Jul-2023

8.3 Result

8.3.1 Readout

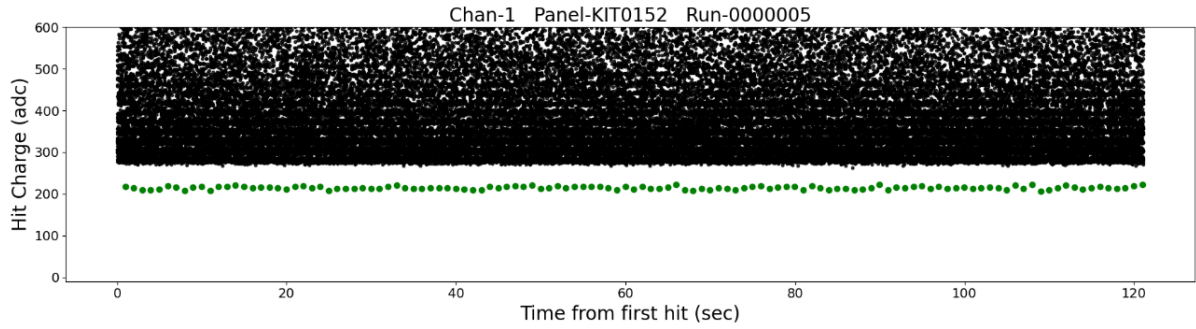

Figure 9 A readout from scintillator panel for 120 second running time

8.3.2 MIP fitting

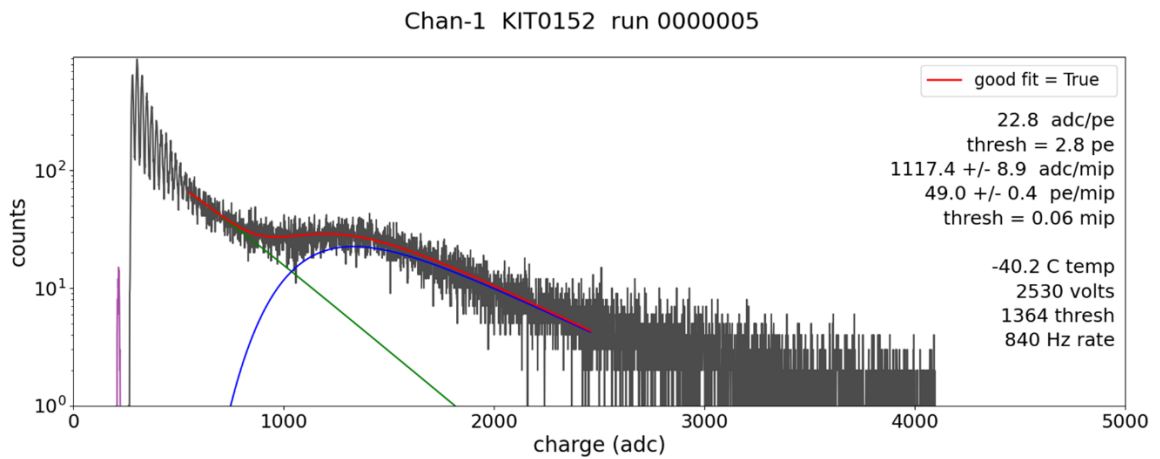

Figure 10 Charge distribution with fitting lines



Name	Wassachon Kammeemoon
Report	Icecube Summer Student Program 2023
Visiting	UW-Madison Wisconsin IceCube Particle Astrophysics Center
Date	1-Jun-2023 to 31-Jul-2023

8.3.3 Temperature and Voltage Scan

Chan-1 KIT0152

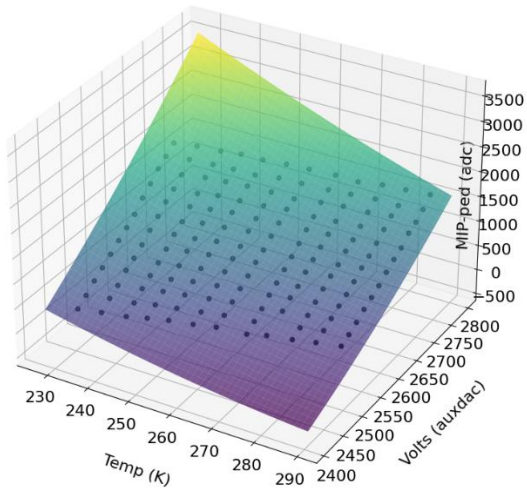

Chan-2 KIT0153

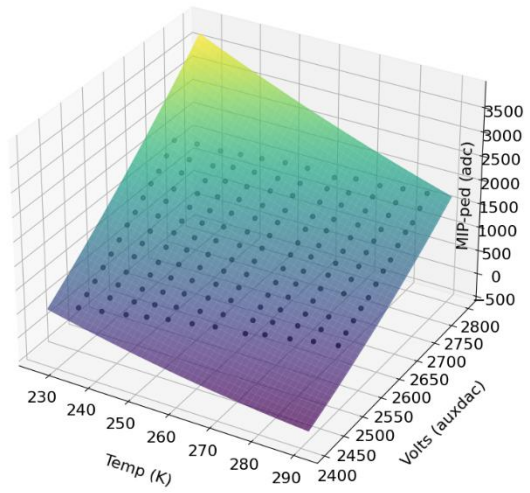

Chan-3 KIT0193

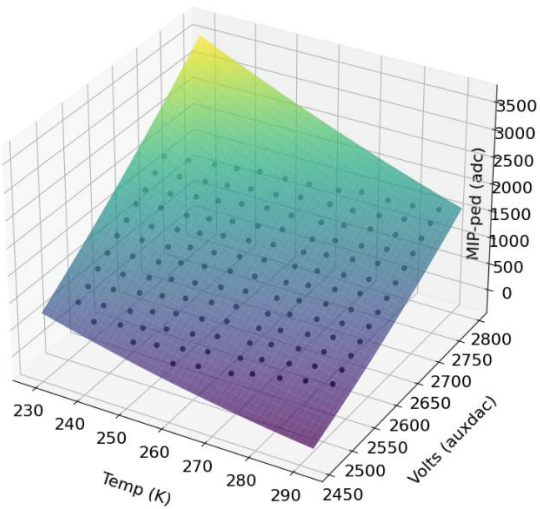

Chan-4 KIT0192

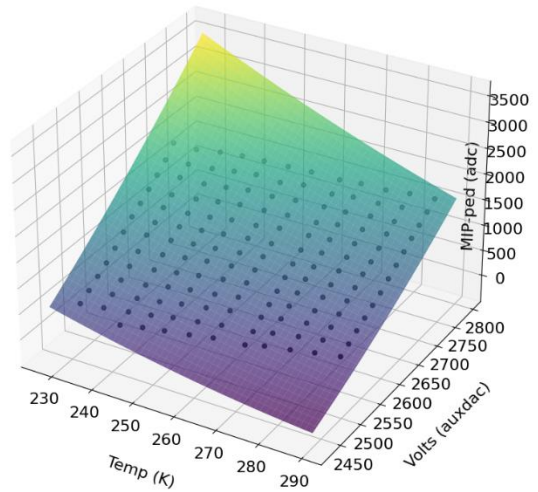



Name	Wassachon Kammeemoon
Report	Icecube Summer Student Program 2023
Visiting	UW-Madison Wisconsin IceCube Particle Astrophysics Center
Date	1-Jun-2023 to 31-Jul-2023

Chan-5 KIT0145

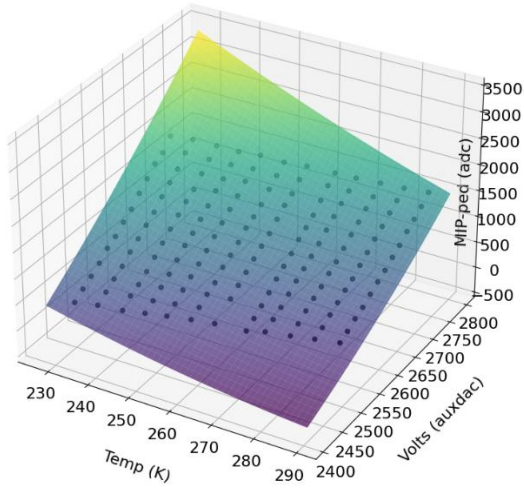

Chan-6 KIT0151

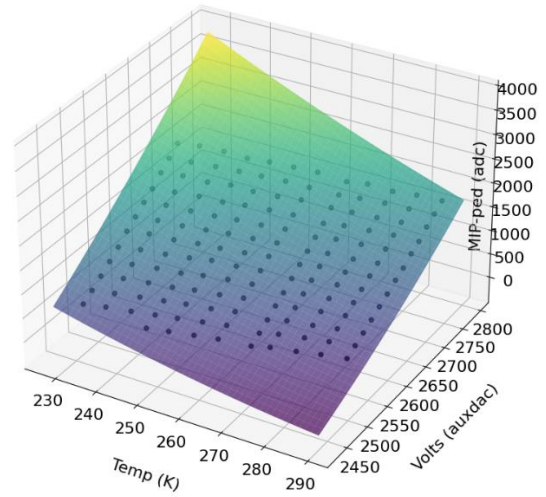

Chan-7 KIT0150

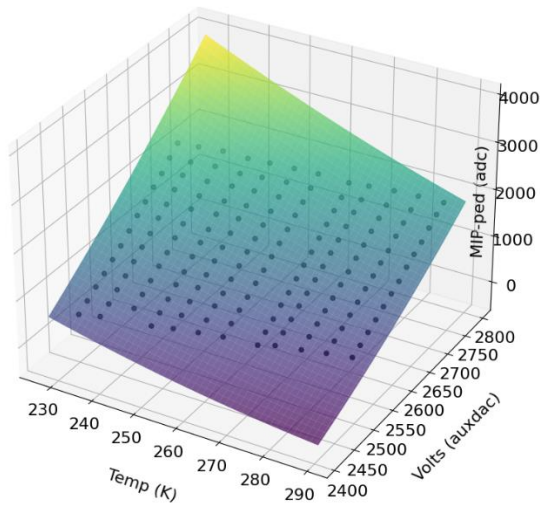

Chan-8 KIT0144

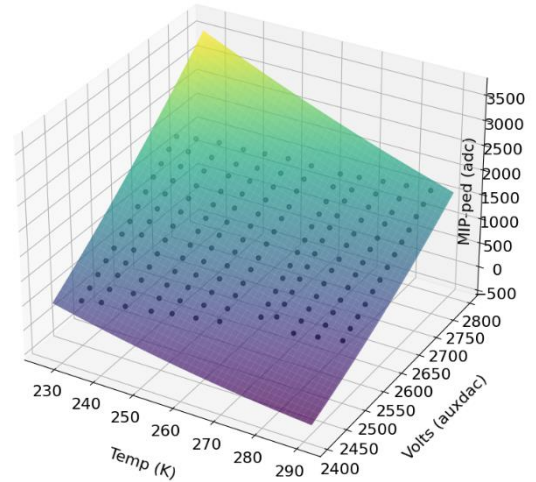

Figure 11 Plots show data from temperature-voltage scan with fitting plane.



Name	Wassachon Kammeemoon
Report	Icecube Summer Student Program 2023
Visiting	UW-Madison Wisconsin IceCube Particle Astrophysics Center
Date	1-Jun-2023 to 31-Jul-2023

8.3.4 Relation between time and freezer temperature

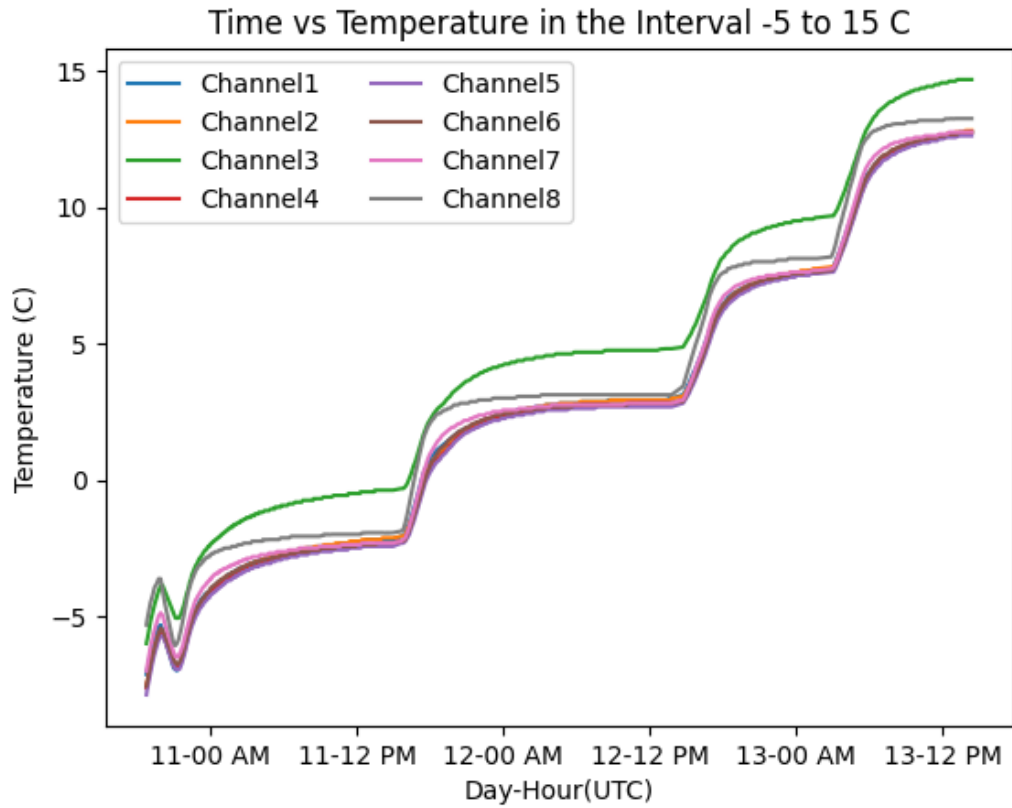

Figure 12 Relationship between time and freezer temperature



Name	Wassachon Kammeemoon
Report	Icecube Summer Student Program 2023
Visiting	UW-Madison Wisconsin IceCube Particle Astrophysics Center
Date	1-Jun-2023 to 31-Jul-2023

8.3.5 Threshold scan

Chan-1 KIT0152

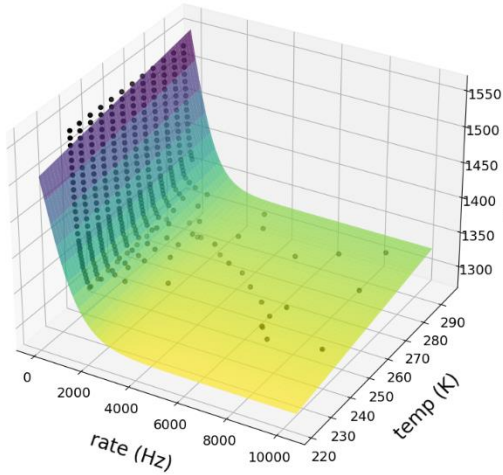

Chan-2 KIT0153

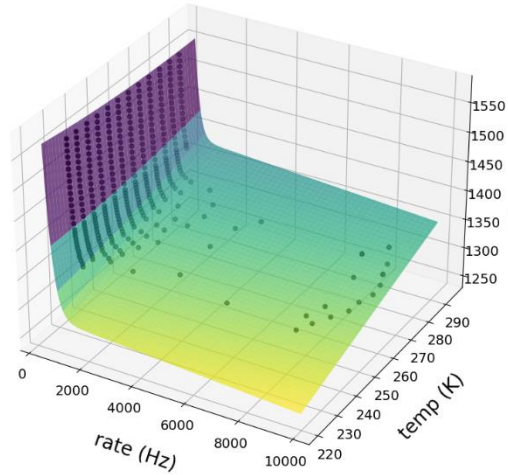

Chan-3 KIT0193

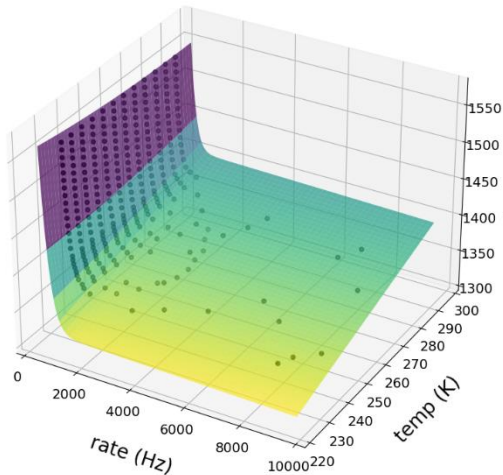

Chan-4 KIT0192

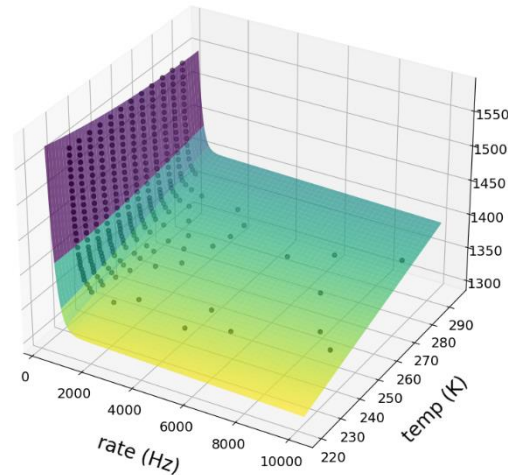



Name	Wassachon Kammeemoon
Report	Icecube Summer Student Program 2023
Visiting	UW-Madison Wisconsin IceCube Particle Astrophysics Center
Date	1-Jun-2023 to 31-Jul-2023

Chan-5 KIT0145

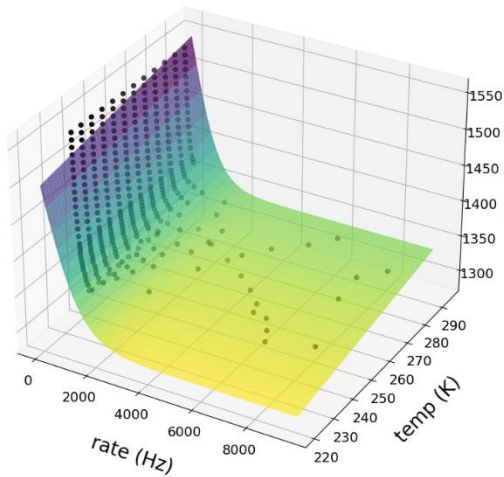

Chan-6 KIT0151

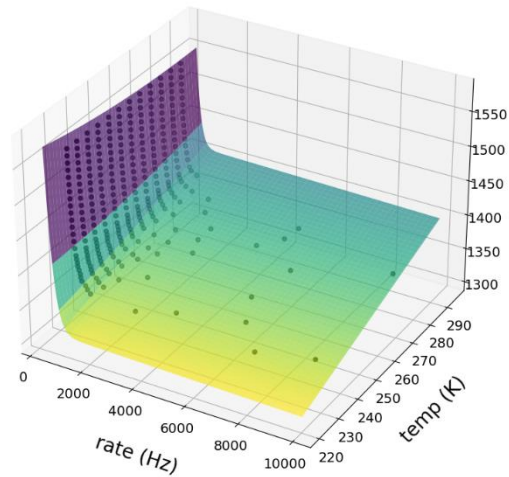

Chan-7 KIT0150

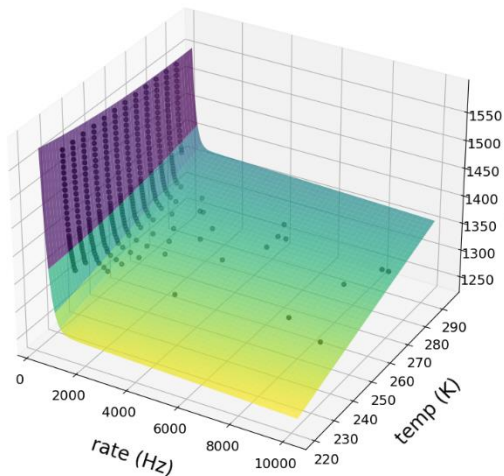

Chan-8 KIT0144

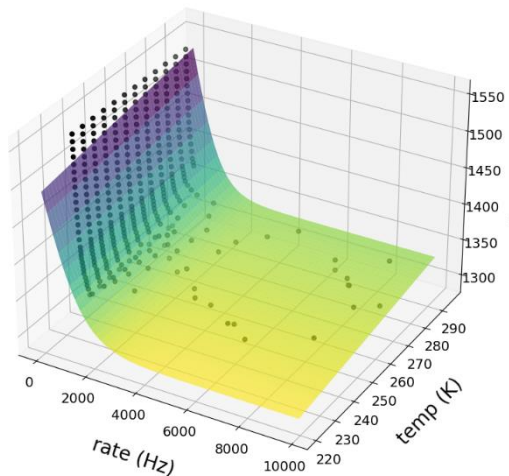

Figure 13 Plots show data from temperature-threshold scan with fitting plane.

8.4 Discussion

Gain is important for electronic devices to maintain the incoming particles data. When gain changes, MIP peak will move. Because of this reason, we use MIP to represent gain for this calibration. The first step of the calibration is to get MIP value. We fit data using Landau's function. From figure 10, Landau function is a combination between linear (exponential) fitting function (green) and gaussian function (blue). If there are not any signals from incoming particles, a charge distribution should be like a green line.

After doing the temperature-voltage scan, we got a relation between temperature (T), voltage (V), and MIP value as following function:

$$\text{MIP} = p[0] + p[1]T + p[2]V + p[3]TV + p[4]T^2 + p[5]V^2$$



Name	Wassachon Kammeemoon
Report	Icecube Summer Student Program 2023
Visiting	UW-Madison Wisconsin IceCube Particle Astrophysics Center
Date	1-Jun-2023 to 31-Jul-2023

Where $p[0]$, $p[1]$, $p[2]$, $p[3]$, $p[4]$, and $p[5]$ are fitting constants. Here are the fitting constants of 8 scintillator panels:

$$P[2] = 0$$

Panel No.: ['p[0]', 'p[1]', 'p[3]', 'p[4]', 'p[5]']

Panel 1: ['-1.0926e+04', '4.6739e+01', '-4.8249e-02', '1.1063e-01', '3.6876e-03']

Panel 2: ['-1.0645e+04', '4.3489e+01', '-4.8545e-02', '1.1706e-01', '3.7454e-03']

Panel 3: ['-1.0612e+04', '4.5313e+01', '-5.1408e-02', '1.2691e-01', '3.8541e-03']

Panel 4: ['-9.1563e+03', '3.5531e+01', '-4.4871e-02', '1.1595e-01', '3.4744e-03']

Panel 5: ['-9.9604e+03', '4.0409e+01', '-4.6292e-02', '1.1358e-01', '3.5611e-03']

Panel 6: ['-9.9318e+03', '4.0615e+01', '-4.5846e-02', '1.1098e-01', '3.5387e-03']

Panel 7: ['-9.9755e+03', '4.1370e+01', '-4.7098e-02', '1.1500e-01', '3.6033e-03']

Panel 8: ['-1.0913e+04', '4.5980e+01', '-4.8711e-02', '1.1216e-01', '3.7629e-03']

These data are fitted with total sigma 1.4% which is acceptable. Moreover, we got a voltage function in term of MIP and temperature.

$$V(T) = \frac{-b + \sqrt{b^2 - 2ac}}{2a}$$

V = Voltage (auxdac)

T = Temperature (K)

$a = p[5]$

$b = p[2] + p[3]T$

$c = MIP - p[0] - p[4]T^2$

After doing the temperature-threshold scan, we got a relation between temperature (T), threshold (Thres), and rate (R) as following function:

$$Thres = \frac{p[0]}{1 + e^{\frac{RT}{p[1]p[2]}}} + p[3] + p[4]R + p[5]T$$

Where $p[0]$, $p[1]$, $p[2]$, $p[3]$, $p[4]$, and $p[5]$ are fitting constants. Here are the fitting constants of 8 scintillator panels:

Panel no. ['p[0]', 'p[1]', 'p[2]', 'p[3]', 'p[4]', 'p[5]']

PANEL1 ['4.3621e+02', '2.3191e+02', '6.9222e+02', '1.1538e+03', '-2.4032e-18', '6.0443e-01']

PANEL2 ['1.9196e+03', '1.5949e+02', '2.8852e+02', '9.8002e+02', '-2.9018e-03', '1.3605e+00']

PANEL3 ['1.6348e+03', '1.6310e+02', '2.9709e+02', '1.0680e+03', '-6.9278e-04', '1.1237e+00']

PANEL4 ['2.0676e+03', '1.5799e+02', '2.6585e+02', '1.0508e+03', '-9.1476e-04', '1.1934e+00']

PANEL5 ['4.1545e+02', '2.2180e+02', '6.8042e+02', '1.1494e+03', '-9.4283e-21', '6.3318e-01']

PANEL6 ['2.0871e+03', '1.5765e+02', '2.6249e+02', '1.0290e+03', '-6.5715e-04', '1.2837e+00']

PANEL7 ['2.5343e+03', '1.7741e+02', '2.2125e+02', '9.1001e+02', '-1.3379e-03', '1.5783e+00']

PANEL8 ['3.9616e+02', '2.2746e+02', '7.2346e+02', '1.1829e+03', '-5.9172e-22', '4.9984e-01']

These data are fitted with total sigma 2.58% which is acceptable.



Name	Wassachon Kammeemoon
Report	Icecube Summer Student Program 2023
Visiting	UW-Madison Wisconsin IceCube Particle Astrophysics Center
Date	1-Jun-2023 to 31-Jul-2023

8.5 References

[1] A. Coleman et al. "First air-shower measurements with the prototype station of the IceCube surface enhancement", 37th International Cosmic Ray Conference (2022), 314.

[2] A. Coleman et al. "Simulation Study of the Observed Radio Emission of Air Showers by the IceTop Surface Extension", 37th International Cosmic Ray Conference (2022), 317.

[3] Agnieszka Stanisława Leszczyńska. "Potential of the IceTop Enhancement with a Scintillation Detector Array". PhD thesis. der KIT-Fakultät für Physik des Karlsruher Instituts für Technologie (KIT), 2020.

[4] M. Oehler et al. "Development of a scintillation and radio hybrid detector array at the South Pole", 37th International Cosmic Ray Conference (2022), 225.

8.6 WIPAC colleagues

- Albrecht Karle, Professor
- Delia Tosi, Assistant Scientist
- John Kelley, Associate Scientist
- Matt Kauer, Assistant Scientist